

# NetCam SC

MULTI-MEGAPIXEL HYBRID IP CAMERAS

- RGB, CMOS, Frame Transfer, Up to 30 FPS, MJPEG
- 5 MP: 2592x1944 / 3 MP: 2048x1536 / 1.3 MP: 1296x976
- Simultaneous IP Network Video & BNC Coaxial Video Output
- Light Sensitivity: 0.3 Lux color, 0 Lux in IR mode (on IR models w/ IR illuminator)
- Video out BNC, allows viewing of video on standard CCTV monitor, MUX, DVR



**VANDAL RESISTANT DOME**  
Indoor/Outdoor Vandal Resistant Design



**HYBRID IP BOX CAMERA**  
Multi-Megapixel Hybrid IP Camera

## FEATURES

- Simultaneous IP Network Video & BNC Coaxial Video Output
- Outputs up to 5 Megapixel, 1080P, 720P and NTSC/PAL
- Up to 15 Times More Resolution than CCTV Cameras
- Operates to -40° Without Heater
- Internal Events trigger NVR / Email / FTP
- Power Over Ethernet, 12VDC or 24VAC
- Available in 1.3, 3 and 5 Megapixel
- Integrated Video Motion Detection
- Automatic Day/Night IR Filter
- DC Auto Iris Support

## IMAGING SPECIFICATIONS

- Day/Night mechanical IR filter mechanism, automatic or manual (on IR models)
- Auto/manual exposure, auto/manual color balance, sharpening, auto/manual haze, defective pixel replacement
- Contrast enhancement, gamma correction, DNR (digital noise reduction), adaptive image resolution (low light)
- Integrated video motion detection with Video-on-Motion bandwidth saver mode
- Lens Mount: Industry standard CS-Mount, (C-Mount compatible)

## OPERATING SYSTEM / CPU

- Built-in web server, telnet server, email client and FTP client
- Supported protocols: TCP/IP, HTTP, FTP, NTP, Telnet, Daytime, X/Y/Zmodem
- 32MB DRAM, 4MB Flash Memory, 32MB Imaging Buffer
- Security: Password-protected user accounts for viewing and configuring NetCam SC



www.stardot.com  
Buena Park, CA USA  
1-877-275-1616  
714-908-2380 • 714-844-4336 fax



# NetCam SC

MULTI-MEGAPIXEL HYBRID IP CAMERAS

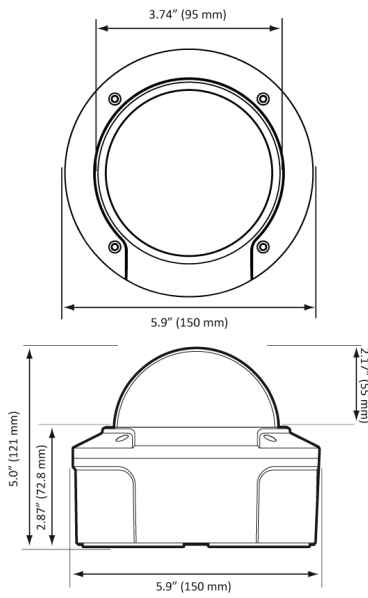

## VANDAL RESISTANT DOME

PHYSICAL	
Dimensions	5.9" Diameter (150mm) x 4.7" H (120mm)
Weight	44 Ounces (1247 grams)
Operating Temp	-40° - +122° F (-40° - +50° C)
<ul style="list-style-type: none"> <li>• Power Requirements: 12VDC/ 24VAC/ POE</li> <li>• EMI Approval: FCC Class A, CE (EN55024)</li> </ul>	
CONNECTIVITY	
<ul style="list-style-type: none"> <li>• 1 x 10/100-baseT, RJ-45, PoE 802.3af (Power over Ethernet)</li> <li>• 1 x BNC Video Output (NTSC/PAL)</li> <li>• 1 x DC Auto Iris Connector</li> <li>• 1 x RS-232 Serial Port, up to 115.2Kb</li> </ul>	
MODELS	
SD500VN	5MP Vandal Resistant Dome with Day/Night
SD500V	5MP Vandal Resistant Dome
SD300V	3MP Vandal Resistant Dome
SD130VN	1.3MP Vandal Resistant Dome with Day/Night
SD130V	1.3MP Vandal Resistant Dome

## OPTIONAL MOUNTS

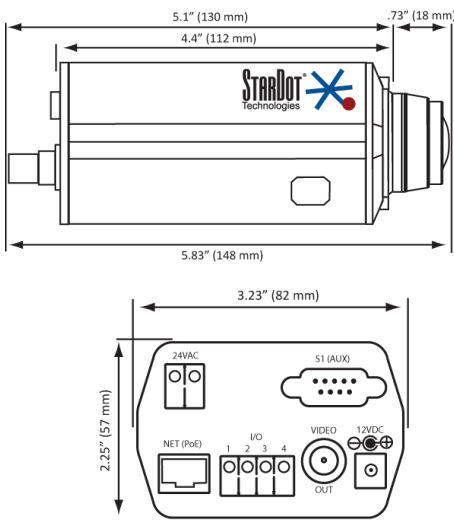
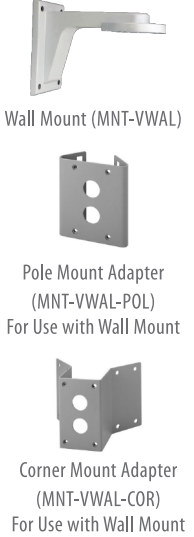

## HYBRID IP BOX CAMERA

PHYSICAL	
Dimensions	3.23"W (82mm) 2.25" H (57mm) 4.4" L (112mm)
Weight	14 Ounces (397 grams)
Operating Temp	-40° - +122° F (-40° - +50° C)
<ul style="list-style-type: none"> <li>• Power Requirements: 12VDC/ 24VAC/ POE</li> <li>• EMI Approval: FCC Class A, CE (EN55024)</li> </ul>	
CONNECTIVITY	
<ul style="list-style-type: none"> <li>• 1 x 10/100-baseT, RJ-45, PoE 802.3af (Power over Ethernet)</li> <li>• 1 x BNC Video Output (NTSC/PAL)</li> <li>• 1 x DC Auto Iris Connector</li> <li>• 1 x RS-232 Serial Port, DB9 Male, up to 115.2Kb</li> <li>• 1 x Fully Isolated Digital Alarm Input</li> <li>• 1 x Fully Isolated Relay Rated at 28VDC 2A or 125VDC 0.5A</li> </ul>	
MODELS	
SD500BN	5MP NetCam SC with Day/Night
SD500B	5MP NetCam SC
SD300B	3MP NetCam SC
SD130BN	1.3MP NetCam SC with Day/Night
SD130B	1.3MP NetCam SC